



PUHY-P750YSJM-A

Standard Y Series 30hp Outdoor Unit

R410A Heat Pump

The City Multi Y Series makes use of a two pipe refrigerant circuit throughout, with the choice of either Branch Pipe or Header Pipe feeds to indoor units, with manual changeover from cooling to heating to ensure that a constant indoor climate is maintained.



Pictures not to scale

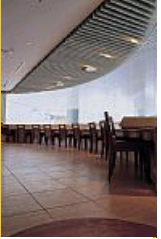

Product Details

PUHY-P750YSJM-A	
Capacity (kW):	
Heating (Nominal)	95.0
Cooling (Nominal)	85.0
Heating (UK)	95.0
Cooling (UK)	78.2
Power Input (kW) Heating (Nominal)	24.67
Power Input (kW) Cooling (Nominal)	24.7
Power Input (kW) Heating (UK)	31.08
Power Input (kW) Cooling (UK)	15.93
Max No. of Connectable Indoor Units	50
Airflow(m ³ /min)	210 /210
Noise (dBA)	63.5
Width - mm	1220 + 1220
Depth - mm	760
Height - mm	1710
Weight - kg	250 + 250
Electrical Supply	380-415v, 50Hz
Phase	3
Mains Cable No. Cores	4 + earth
Starting Current (A)	8
Running Current (A) - Heating	38.1
Running Current (A) - Cooling	38.1

Piping Restrictions

Total Piping Length (m)	1000
Furthest Piping Length (m)	165
Furthest Piping Length after 1st Branch (m)	40
Between Indoor and Outdoor Units - Height (m)	50
Between Indoor and Indoor Units - Height (m)	15

Dimensions

PUHY-P750YSJM-A

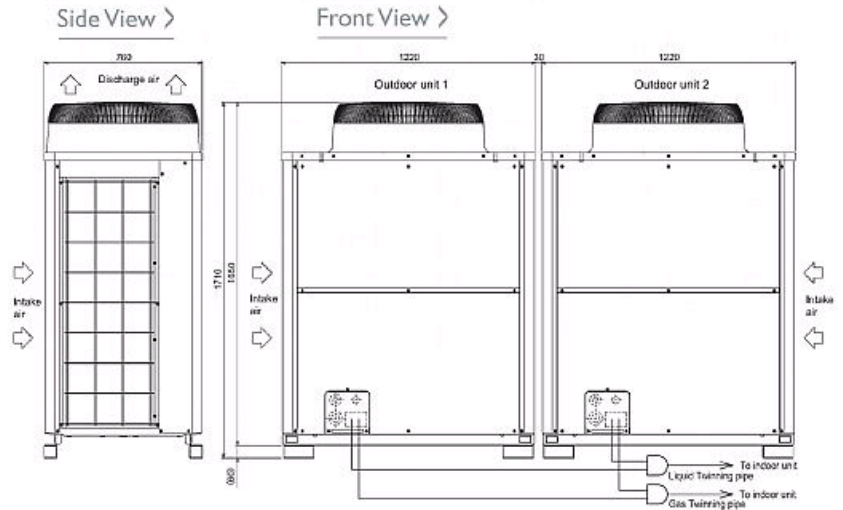

Telephone: 01707 282880

Email: air.conditioning@meuk.mee.com Website: <http://www.mitsubishielectric.co.uk/aircon>

Mitsubishi Electric reserves the right to make any variation in technical specification to the equipment described, or to withdraw or replace products without prior notification or public announcement.

Tel:
Fax:

